

# Bearing Repeater Compass

---



# Bearing Repeater Compass

The Bearing Repeater Compass is equipped with a 360° compass card and a digital display for heading indication. The heading source – gyro compass, magnetic compass or satellite compass – is also indicated.

Bearing sights can be easily mounted on the centric adapter. The reflected 360° dial on the compass card is used for the reflection into the bearing sight. A fixed 360° scale on the outer ring allows relative bearings to be taken.

For use on double-end ferries a 180° offset can be added. Illumination is controlled via push-button. Bearing sights, bearing brackets and a pelorus stand are available.



## Bearing sight CP 190

- Hinged wire and slit vane for exact bearings
- Index marks for reading the relative bearings on the gradual scale of the repeater compass
- Glass prism and index wire to read compass bearings on the gradual scale of the repeater compass
- Mirror for astronomical bearings
- Two hinged tinted filters (black) for direct sun observation
- The bearing sight comes in a protective case for safe-keeping



## Terrestrial and astronomical bearings

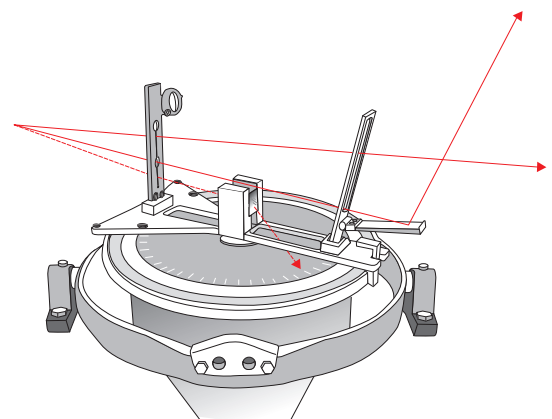
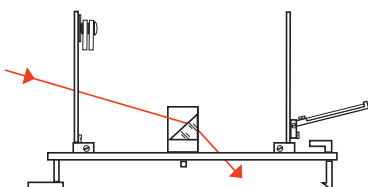

## Standard bearing sight

- Index marks for reading the relative bearings on the gradual scale of the repeater compass
- High reading accuracy due to internal optical path
- Mirror for astronomical bearings
- Hinged tinted filter (black) for direct sun observation
- Level indicator for horizontal alignment of the bearing repeater
- Solid design without wires
- The bearing sight is delivered in a protective case for safe-keeping

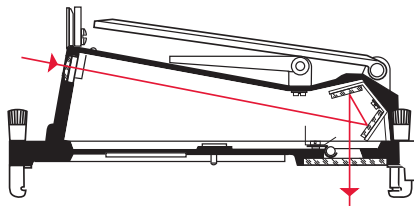

## Telescoping bearing sight

- Bearing sight with seven times optical magnification
- Ocular with diopetre adjustment
- High quality night optics
- Direct reflecting of compass card into field of view for direct reading of bearing
- Mirror for astronomical bearings and seven times power magnification
- Three hinged tinted filters (yellow, grey, black)
- Level indicator for horizontal alignment of the bearing repeater
- Taking of bearings without use of optics
- Solid design without wires
- The bearing sight is delivered in a protective case for safe-keeping

### Terrestrial bearing

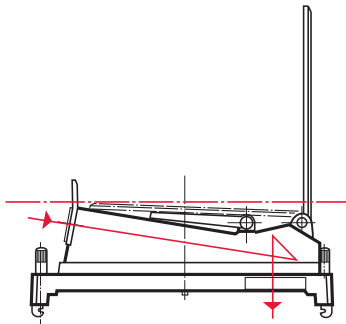

### Terrestrial bearing

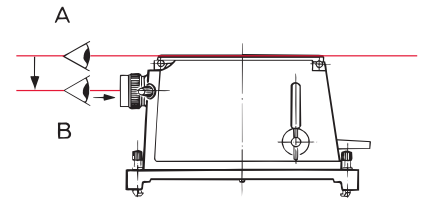
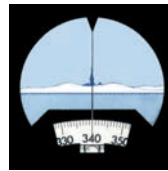

### Astronomical bearing

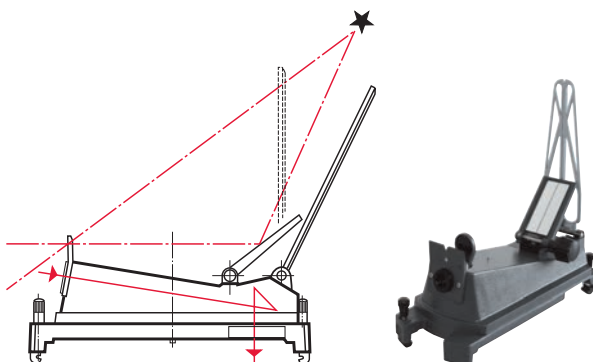

### Astronomical bearing

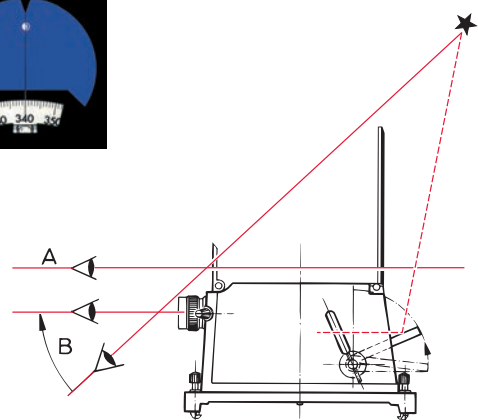

## Reading accuracy

- 0.5° on compass card
- 0.1° on digital display

## Supply voltage & power consumption

- 24 V DC (18 – 36 V DC)
- max. 10 W

## Signal input for heading

- HDT, HDG, HDM
- Course Bus

## Permissible ambient temperature

- -25° C to +70° C

## Type of enclosure acc. to IEC/EN 60529

- IP 56

## In accordance with

- EN/IEC 60945
- EN/IEC 61162

## Bearing bracket, non adjustable

Weight: 8 kg

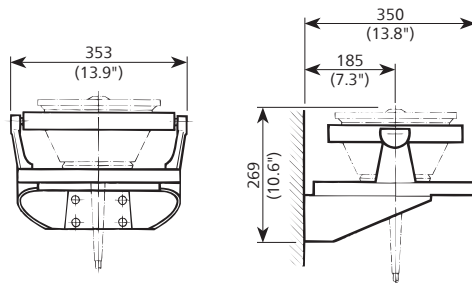

## Bearing bracket, adjustable

Weight: 13 kg

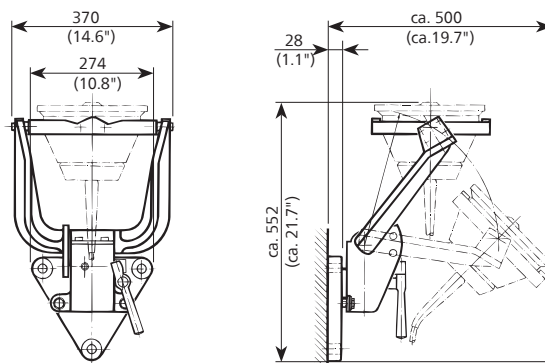

## Bearing Repeater Compass

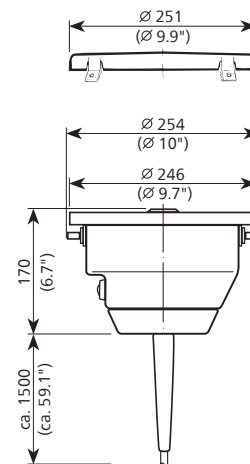

## Pelorus stand

Weight: 34 kg

